

***DP-5609UF***

HIGH FREQUENCY DIFFERENTIAL PROBE

差動測試棒

## **Instruction Manual**



# TABLE OF CONTENTS

<b>GENERAL SAFETY SUMMARY</b>	<b>1</b>
Safety Precautions	1
Explanation of Symbols	2
Compliance Information	2
<b>PRODUCT INTRODUCTION</b>	<b>3</b>
Description of the Instrument and Accessories	4
Electrical Specifications	5
General Specifications	5
<b>OPERATING INFORMATION</b>	<b>6</b>
Connecting to the Instrument	6
Disconnecting from the Instrument	7
Bandwidth Limit	7
Twisting the Input Leads	7
External Power Source	8
Derating Curve	8
<b>MAINTENANCE</b>	<b>9</b>
Cleaning	9
Warranty	9
Repair	9
<b>ATTACHED (Standard accessories)</b>	<b>19</b>

## 目次

<b>一般安全概要</b>	<b>10</b>
安全注意事項	10
符號說明	10
安規說明	11
<b>產品介紹</b>	<b>12</b>
儀器及附件說明	13
電氣規格	14
一般規格	14
<b>操作說明</b>	<b>15</b>
連接到儀器	15
斷開與儀器連接	16
頻寬限制	16
輸入引線絞線	16
外部電源	17
降額曲線	17
<b>產品維護</b>	<b>18</b>
<b>附圖 (標準附件示意圖)</b>	<b>19</b>

## GENERAL SAFETY SUMMARY

- Review the following safety precautions to avoid injury and prevent damage to this product or any products connected to it. To avoid potential hazards, use this product only as specified.
- Only qualified personnel should perform service procedures.



### **Safety Precautions: to avoid fire or personal injury**

**Use proper power cord.** Use only the power cord specified for this product and certified for the country of use.

**Connect and disconnect properly.** Do not connect or disconnect probes or test leads while they are connected to a voltage source.

**Connect and disconnect properly.** Connect the probe output to the measurement instrument before connecting the probe to the circuit under test. Connect the probe lead to the circuit under test before connecting the probe input. Disconnect the probe input and the probe lead from the circuit under test before disconnecting the probe from the measurement instrument.

**Ground the product.** This product is indirectly grounded through the grounding conductor of the mainframe power cord. To avoid electric shock, the grounding conductor must be connected to earth ground. Before making connections to the input or output terminals of the product, ensure that the product is properly grounded.

**Observe all terminal ratings.** To avoid fire or shock hazard, observe all ratings and markings on the product. Consult the product manual for further ratings information before making connections to the product.

Do not apply a potential to any terminal, including the common terminal, that exceeds the maximum rating of that terminal.

#### **Respect the max input voltages:**

1. Max differential voltage:  $\pm 260$  V (DC + AC peak) or 183 Vrms.
2. Max voltage between each input terminal and ground: 91.5 Vrms.

**Power disconnects.** The power cord disconnects the product from the power source. Do not block the power cord; it must remain accessible to the user at all times.

**Do not operate without covers.** Do not operate this product with covers or panels removed.

**Do not operate with suspected failures.** If you suspect that there is damage to this product, have it inspected by qualified service personnel.

**Avoid exposed circuitry.** Do not touch exposed connections and components when power is present.

**Use proper AC adapter.** Use only the AC adapter specified for this product.

**Do not operate in wet/damp conditions.**

**Do not operate in an explosive atmosphere. Keep product surfaces clean and dry.**

## Explanation of Symbols

The following symbol(s) may appear on the product:



Attention refers to operation Instructions.



Dangerous voltage may be present at terminals.



This instrument has double insulation.

## Compliance Information

This product complies with the following safety regulations:

Electrical Safety to IEC 61010-1:

- Dual Insulation
- Installation Category III
- Pollution Degree 2. (Note: Rated for indoor use only)
- Rated Voltage or Max Live-Earth: 91.5 Vrms



CE Mark: conforms to EN 50081-1 and 50082-1 standards.

## PRODUCT INTRODUCTION

The DP-5609UF differential voltage probes provide a safety means of measuring floating potentials for all models of oscilloscopes incomplete safety.

It converts the differential voltage ( $\leq \pm 260$  DC+AC peak) into a low voltage ( $\leq \pm 26$  V) with reference to the earth for display on the oscilloscopes.

The BNC output is designed to operate on an input with an impedance of 1 M $\Omega$ . It is 2 times of the 50  $\Omega$ .

DP-5609UF is designed for high frequency module and high dynamic range. Attenuation X10, X100, which is easy for calculation without mistake. Maximum voltage is 520 Vp-p. This is designed for high voltage.

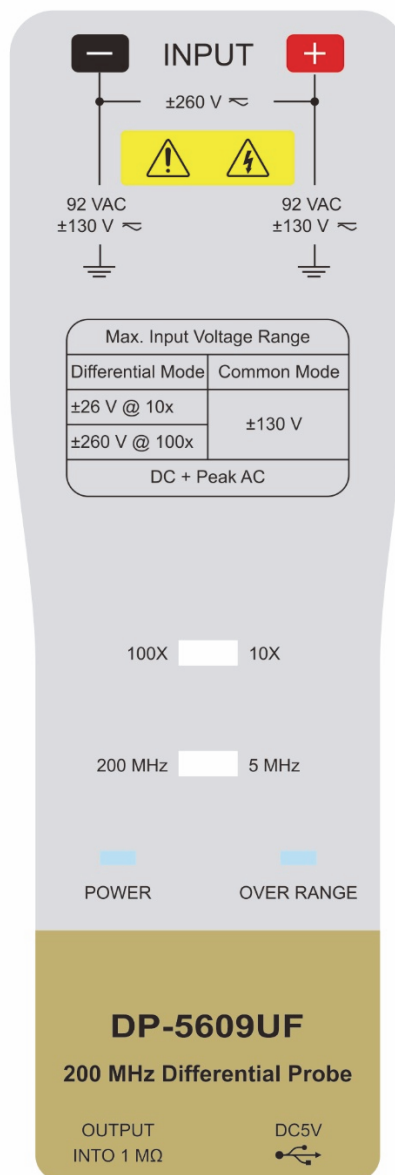

Model	Bandwidth	Attenuation	Oscilloscope interface
DP-5609UF	200 MHz	X10 / X100	BNC

## Description of the Instrument and Accessories



Model: DP-5609UF

- |  |   |
|--|---|
| ① Integral Input Leads                 | ② Attenuation Function Switch           |
| ③ Bandwidth Function Switch            | ④ Power On/Off Indication               |
| ⑤ Overrange Indication                 | ⑥ Output Connector/ BNC Cable           |
| ⑦ External Power Source [DC 5 V]       | ⑧ USB Cable (USB-510) [L=100 cm]        |
| ⑨ Extender Leads (ETL-2100) [L=100 cm] | ⑩ Hook Clips (BP-256A)                  |
| ⑪ Test Probes (BP-286N)                | ⑫ Alligator Clips (BP-276N)             |
| ⑬ AC adapter (optional) [100~240 V]    | ⑭ Plug Converter (PLUG-220) [100~240 V] |

## Electrical Specifications

Function/ Model	DP-5609UF
Bandwidth (-3dB)	DC to 200 MHz
Attenuation	X10 / X100
Accuracy	$\leq \pm 2\%$
Voltage Input Ranges	$\leq \pm 26$ V (DC + AC peak) for X10, (i.e about 18 Vrms) $\leq \pm 260$ V (DC + AC peak) for X100, (i.e about 183 Vrms)
Permitted Max. Input Voltage	Max differential voltage: $\pm 260$ V (DC + AC peak) Max voltage between each input terminal and ground: 91.5 Vrms
Input Impedance	1 M $\Omega$ // 1 pF each side to ground
Output Voltage	$\leq \pm 2.6$ V
Output Impedance	50 $\Omega$ (for 1 M $\Omega$ input oscilloscope)
Rise Time	$\approx 1.75$ nS
Rejection Rate on Common Mode	60 Hz: > 80 dB / 100 Hz: > 60 dB / 1 MHz: > 50 dB
5 MHz Limit Bandwidth	Switchable: Full / 5 MHz

## General Specifications

Model	DP-5609UF
Power Supply	External 5 V DC (USB Input), consumption about 300 mA
Dimensions	175 x 68 x 28 mm
Weight	285 g
Temperature	Reference: +20 °C ~ +30 °C Use: 0 °C ~ +50 °C Storage: -30 °C ~ +70 °C
Relative Humidity	Reference: $\leq 70\%$ RH Use: 10% ~ 85% RH Storage: 10% ~ 90% RH
Accessories	Extender leads x 2 pcs, Hook clips x 2 pcs, Alligator clips x 2 pcs, Test probes x 2 pcs, USB cable x 1 pc, Plug convertor x 1 pc, AC adapter x 1 pc

## OPERATING INFORMATION

### Connecting to the Instrument

1. Connect the probe input lead to the circuit under test and ensure that the probe is positioned at a right angle to the circuit under test.
2. Connect the probe to the oscilloscope with the insulated BNC cable.

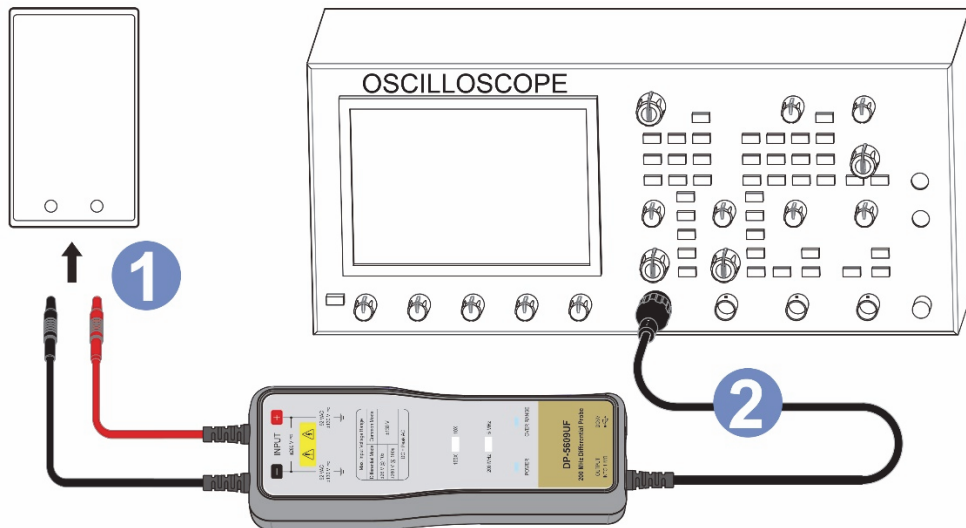

Figure1.

3. Adjust the vertical zero adjustment of the oscilloscope if necessary.
4. Select the attenuation ratio and the vertical deviation of the oscilloscope in accordance with the conversion table1.
5. The POWER light must be on.

**table1. The conversion table gives the real vertical deviation:**

Attenuation	X100	X10
MAX Voltage Input Range (DC+AC Peak)	± 260 V	± 26 V
DC MAX INPUT	± 260 V	± 26 V
AC RMS MAX INPUT	183 Vrms	18 Vrms

Vertical deviation on the oscilloscope in V/div	Real Deviation In V/div	
	X100 Range	X10 Range
1	100	10
0.5	50	5
0.2	20	2
0.1	10	1
50 m	5	0.5
20 m	2	0.2
10 m	1	0.1
5 m	0.5	50 m
2 m	0.2	20 m





**NOTE.** The real vertical deviation in V/div is equal to the attenuation factor multiplied by the range of vertical deviation selected on the oscilloscope. It will be doubled in the case of use of a 50 Ω load.

**Example:**

With the probe on factor X100, the oscilloscope on 0.5 V/div, the real vertical deviation is  $100 \times 0.5 = 50$  V/div.

With a 50 Ω load on the input of the oscilloscope the deviation becomes 25 V/div

## Disconnecting from the Instrument



**WARNING.** To avoid electrical shock, disconnect the probe inputs from the circuit before disconnecting the probe from the instrument.

1. Turn the probe connector counterclockwise.
2. Pull straight out.

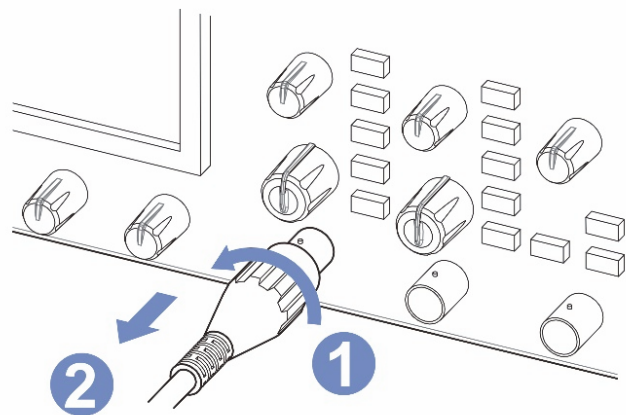

Figure2.

## Bandwidth Limit

Slide the Bandwidth limit switch to limit the probe bandwidth to 5 MHz. The 5 MHz filter assists in the characterization and testing of power supplies in switch mode by removing all high frequency content, noise and harmonics from the measurement.

## Twisting the Input Leads

Twisting the input leads helps to cancel noise from high-EMI environments that is induced into the input leads.

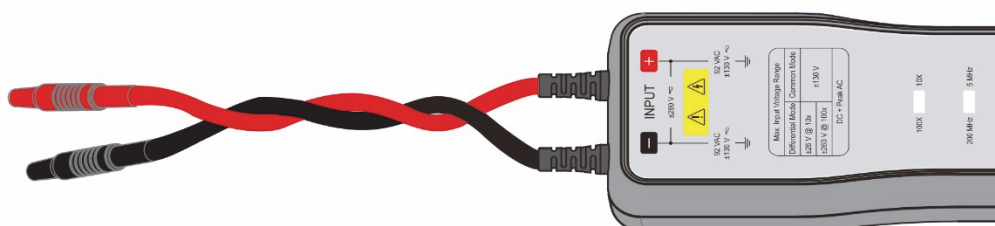

Figure3.

### External Power Source

Power consumption of the probe is about 500 mA, thus it no suit for battery, please use the accessory adaptor only. (Refer Figure4.)

If there are any damage on the adaptor, please contact us and use the adaptor supplied by us only. If the input power over 6 VDC will cause hard damage.

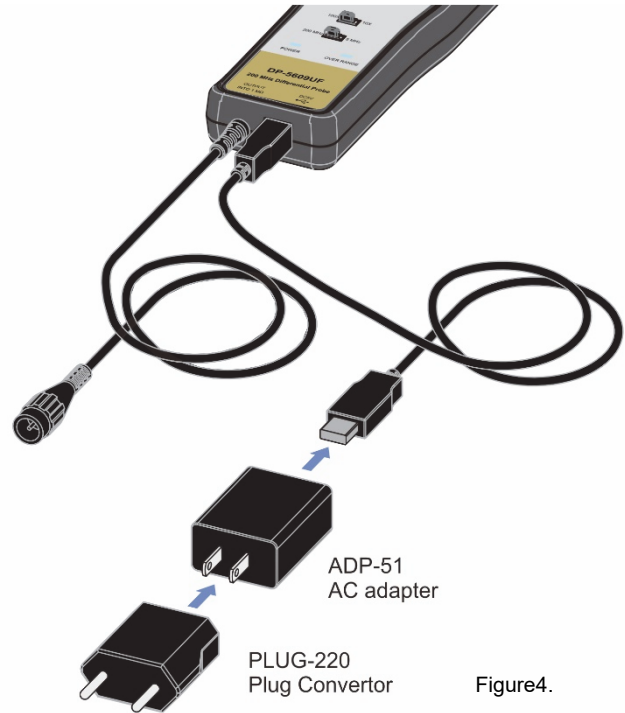
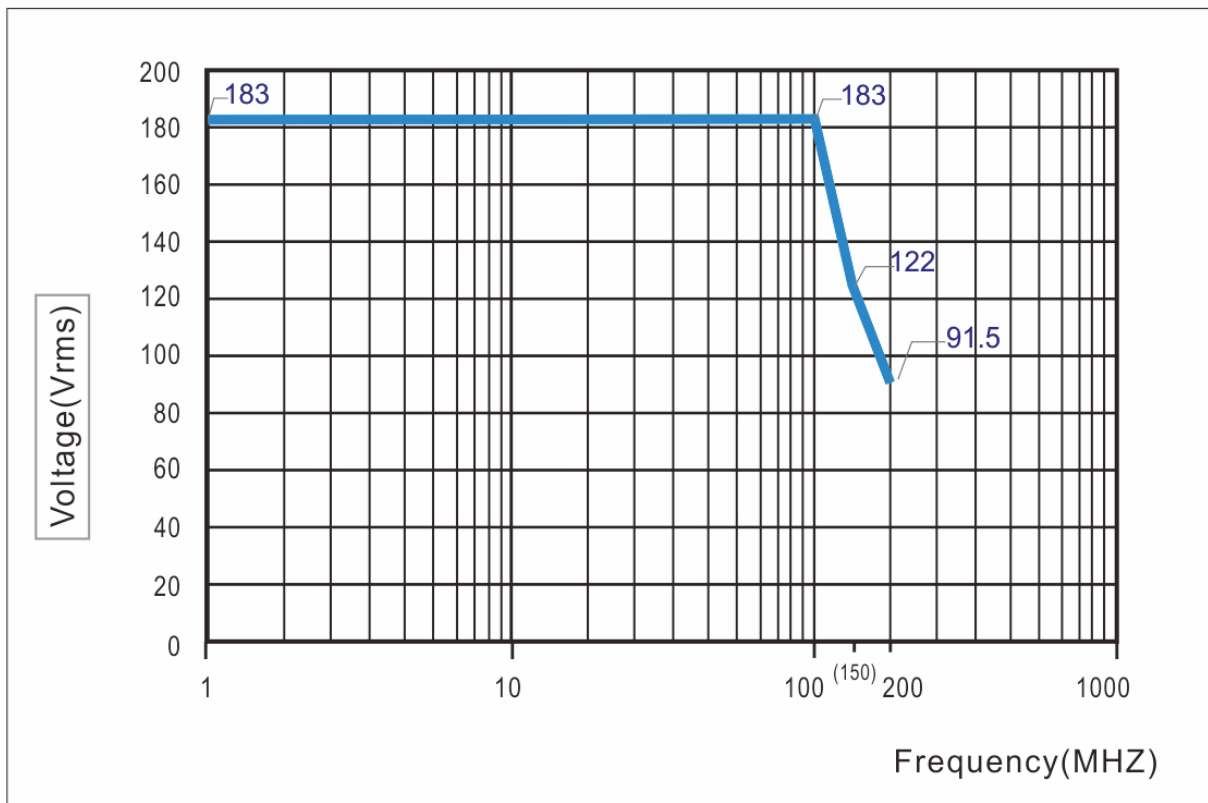

Figure4.

### Derating Curve

The DP-5609UF derating curve of the absolute maximum input voltage in differential mode is shown as below.



## **MAINTENANCE**

For maintenance, only use specified spare parts.

The manufacturer can't be held responsible for any accident arising following a repair made other than its after sales service or approved repairers.

### **Cleaning**

This probe does not require any particular cleaning. If necessary, clean the case with a cloth slightly moistened with soapy water.

### **Warranty**

Unless notified to the contrary, our instruments are guaranteed against any manufacturing defect or material defect. They do not bear the specification known as the safety specification. Our guarantee, which may not under any circumstances exceed the amount of the invoiced price, goes no further than the repair of our faulty equipment, carriage paid to our workshops.

### **Repair**

Maintenance, repairs under or out of guarantee. Please return to product to your distributor.

## 一般安全概要

- 使用本產品前，請先查看以下安全預防措施，以避免受傷並防止損壞本產品或與其相連的設備。為避免潛在危險，請僅按規定使用本產品。
- 只有合格的人員才能執行維修程序。



### 安全注意事項：避免火災或人身傷害

**使用合適的電源線。** 僅使用為本產品指定並經使用國家/地區認證的電源線。

**正確連接和斷開連接。** 當測試棒或測試線連接到電壓源時，不要連接或斷開它們。

**正確連接和斷開連接。** 在將測試棒連接到被測電路之前，請先將測試棒輸出端連接到測量儀器。在連接測試棒輸入之前，請將測試棒引線連接到被測電路。在將測試棒與測量儀器斷開連接之前，請將測試棒輸入端和測試棒引線與被測電路斷開。

**將產品接地。** 本產品通過主機電源線的接地導體間接地。為避免觸電，接地導體必須接地。在連接產品的輸入或輸出端子之前，請確保產品正確接地。

**遵守所有端子額定值。** 為避免火災或電擊危險，請遵守產品上的所有額定值和標記。在連接到產品之前，請查閱產品手冊以獲取更多額定值信息。

請勿對任何端子（包括公共端子）施加超過該端子最大額定值的電位。

**遵守最大輸入電壓：**

1. 最大差動電壓： $\pm 260 \text{ V}$  (DC + AC 峰值) 或 183 Vrms。
2. 輸入端與接地端之間的最大差動電壓：91.5 Vrms。

**斷開電源。** 不要阻塞或遮蓋電源線，電源線必須隨時能斷開產品與電源的連接。

**不要在沒有蓋子的情況下操作。** 請勿在移除蓋板或面板的情況下操作本產品。

**不要在疑似故障的情況下進行操作。** 如果您懷疑本產品有損壞，請讓合格的維修人員對其進行檢查。

**避免電路暴露。** 通電時請勿觸摸有裸露電路的連接物和組件。

**使用合適的適配器。** 僅使用為本產品指定的 AC 適配器。

請勿在潮濕/潮濕的環境條件下操作。

請勿在易爆炸的環境中操作。請保持產品表面清潔乾燥。

## 符號說明

產品上可能會出現以下符號：



注意並參見操作說明。



接線端子上可能存在危險電壓。



本儀器具有雙重絕緣。

## 安規說明

本產品符合以下安全規定：

符合 IEC 61010-1 的電氣安全：

- 雙重絕緣
- 安裝類目 III
- 污染等級 2 (注：額定僅適用於室內使用)。
- 額定電壓或最大接地電壓：91.5 Vrms

 CE 標誌：符合 EN 50081-1 和 50082-1 標準

## 產品介紹

DP-5609UF 差動測試棒提供一個安全的絕緣儀器給所有的示波器使用，它可以轉換由輸入的差動電壓( $\leq \pm 260$  DC + AC peak) 進入一個低電壓( $\leq \pm 26$  V) 並且顯示波形在示波器上，使用頻率高達 200 MHz，非常適合測試、研發使用。

差動測試棒輸出標示是設計在操作示波器 1 M $\Omega$  的輸入阻抗的相對衰減量，當使用 50  $\Omega$  匹配器時衰減量剛好為 2 倍量。

DP-5609UF 為一高頻率設計，衰減器 X10，X100 皆方便使用者計算，且不容易出錯，其最高電壓達到 520 Vp-p，為一高電壓設計的機種。

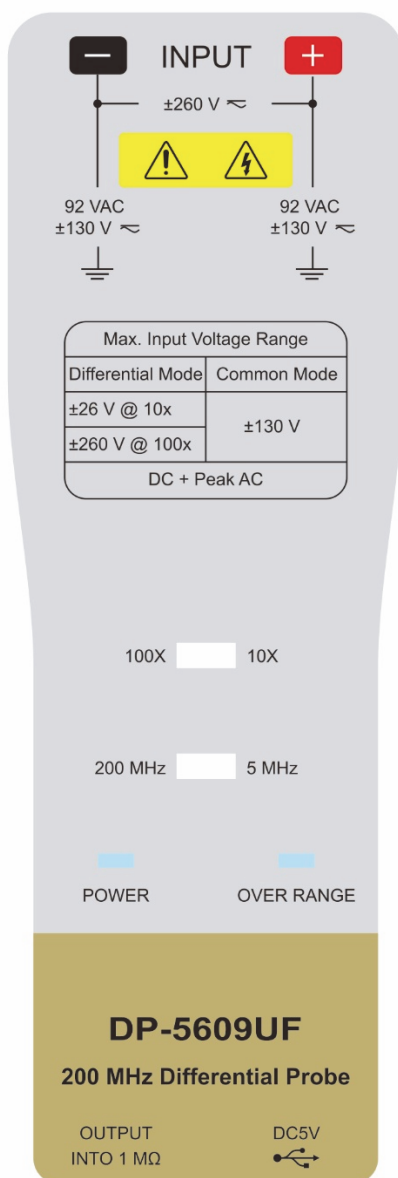

產品型號	頻寬	衰減	示波器連接界面
DP-5609UF	200 MHz	X10 / X100	BNC

儀器及附件說明



適用型號: DP-5609UF

- |                              |                                |
|------------------------------|--------------------------------|
| ① 一體式輸入引線                    | ② 衰減量選擇開關                      |
| ③ 頻寬選擇開關                     | ④ 電源開/關指示燈                     |
| ⑤ 過載警示燈                      | ⑥ 輸出連接器/ BNC 電纜                |
| ⑦ 外部電源輸入端 [DC 5 V]           | ⑧ USB 傳輸線 (USB-510) [L=100 cm] |
| ⑨ 延長線 (ETL-2100)[L=100 cm]   | ⑩ 鉤夾(BP-256A)                  |
| ⑪ 測試棒 (BP-286N)              | ⑫ 鱷魚夾 (BP-276N)                |
| ⑬ AC 轉換器(適配器)(選購)[100~240 V] | ⑭ 插頭轉換器(PLUG-220)[100~240 V]   |

## 電氣規格

功能/ 型號	<b>DP-5609UF</b>
頻寬(-3 dB)	DC to 200 MHz
衰減	X10 / X100
精確度	$\leq \pm 2\%$
輸入電壓範圍	$\leq \pm 26$ V (DC + AC peak) X10 檔, (約 18 Vrms) $\leq \pm 260$ V (DC + AC peak) X100 檔, (約 183 Vrms)
允許最高輸入電壓	最高差動電壓: $\pm 260$ V (DC + AC peak) 輸入端及接地端間最高電壓: 91.5 Vrms
輸入阻抗	各單端到接地端間的輸入阻抗: $1$ M $\Omega$ // 1pF
輸出電壓	$\leq \pm 2.6$ V
輸出阻抗	50 $\Omega$ (在 1 M $\Omega$ 輸入阻抗的示波器系統中)
上升時間	$\approx 1.75$ nS
雜訊抑制率	60 Hz: > 80 dB / 100 Hz: > 60 dB / 1 MHz: > 50 dB
5 MHz 限制頻寬	可切換: Full / 5 MHz

## 一般規格

型號	<b>DP-5609UF</b>
電源	指定外接 5 VDC 電源 (必須使用本公司指定品) 最大耗電量約 300 mA
尺寸(不含引線)	175 x 68 x 28 mm
重量	285 g
溫度	一般狀態: +20 °C ~ +30 °C 操作環境: 0 °C ~ +50 °C 儲存環境: -30 °C ~ +70 °C
相對溼度	一般狀態: $\leq 70$ %RH 操作環境: 10% ~ 85% RH 儲存環境: 10% ~ 90% RH
標準附件	延長線 x 紅黑各 1, 鉤夾 x 紅黑各 1, 鱷魚夾 x 紅黑各 1, 測試棒 x 紅黑各 1, USB 連接線 x 1 條, 插頭轉換器 x 1 個, AC 轉換器(適配器) x 1 個



## 操作說明

### 連接到儀器

1. 將鉤夾 BP-256A (或鱷魚夾 BP-276N) 插入差動測試棒的輸入端引線，並將鉤夾 BP-256A (或鱷魚夾 BP-276N) 與測量電路接觸同時保持測試棒與測試電路呈直角。
2. 將差動測試棒的輸出端接上 BNC 電纜後連結到示波器。



圖 1.

3. 如有需要先調整示波器上的垂直開關。
4. 將示波器上的衰減率及垂直開關調整到一致的位置，如表格 1. 所示。
5. 注意！電源必須打開。

表格 1. 垂直偏差換算表

衰減	X100	X10
最大輸入電壓(DC+AC Peak)	± 260 V	± 26 V
DC 最大輸入值	± 260 V	± 26 V
AC 最大輸入值	183 Vrms	18 Vrms

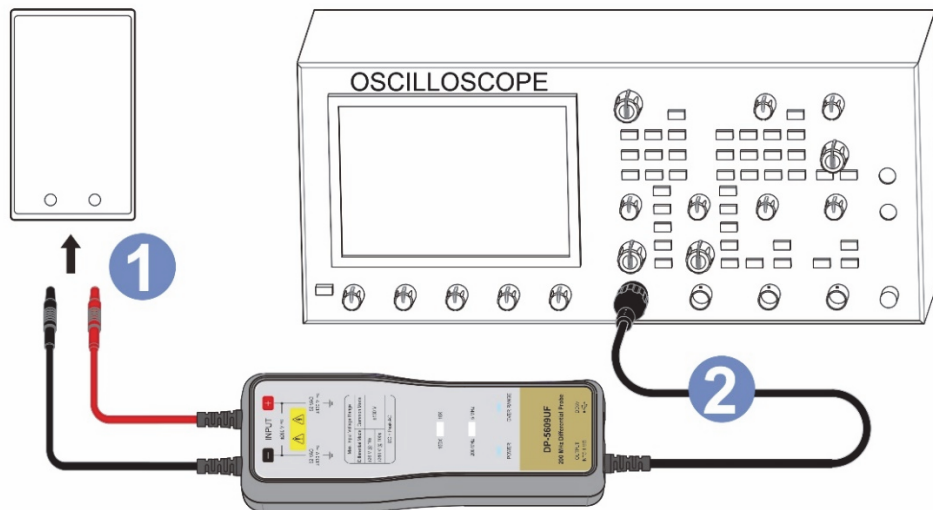
示波器上的垂直偏向 V/div	換算實際偏向 V/div	
	X100 檔	X10 檔
1	100	10
0.5	50	5
0.2	20	2
0.1	10	1
50 m	5	0.5
20 m	2	0.2
10 m	1	0.1
5 m	0.5	50 m
2 m	0.2	20 m



**注意!** 實際的垂直偏向是等於衰減乘上示波器上所選擇的垂直偏向，如果另外使用  $50\ \Omega$  負載端子時，實際電壓值剛好是 2 倍量。

例如:

測試棒是 X100，示波器的垂直偏向在  $0.5\ \text{V/div}$ ，其實際的垂直偏向為  $100 \times 0.5 = 50\ \text{V/div}$

示波器輸入的負載是  $50\ \Omega$ ，偏向就為  $25\ \text{V/div}$

## 斷開與儀器連接



**警告!** 為避免電擊，在將測試棒與儀器斷開連接之前，請先將測試棒與電路斷開。

1. 逆時針轉動 BNC 接頭。
2. 直接拉出 BNC 接頭。



圖 2.

## 頻寬限制

切換 Bandwidth Limit 開關，可以將輸出頻寬限制在  $5\ \text{MHz}$ 。啟用頻寬過濾器後，可以有效去除所有的高頻內容、諧振、雜訊、簡化輸出波形。

## 輸入引線絞線

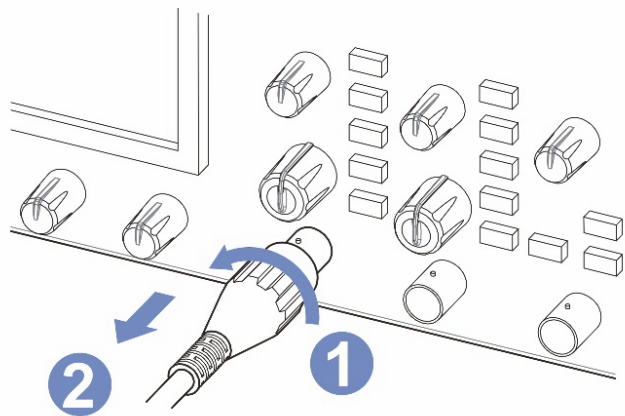
量測時將輸入線絞線，可以有效避免環境電磁干擾與雜訊。



圖 3.

## 外部電源

測試棒的功耗約為 500 mA，因此不適合使用電池，請僅使用附件轉換器(適配器)連接電源。(圖 4.)

如果電源轉換器(適配器)有任何損壞，請與我們聯繫並僅使用我們提供的轉換器(適配器)。

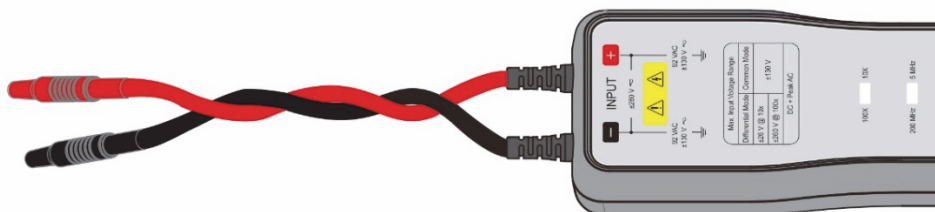
**注意!** 如果輸入電源超過 6 VDC 會導致測試棒造成硬損壞。

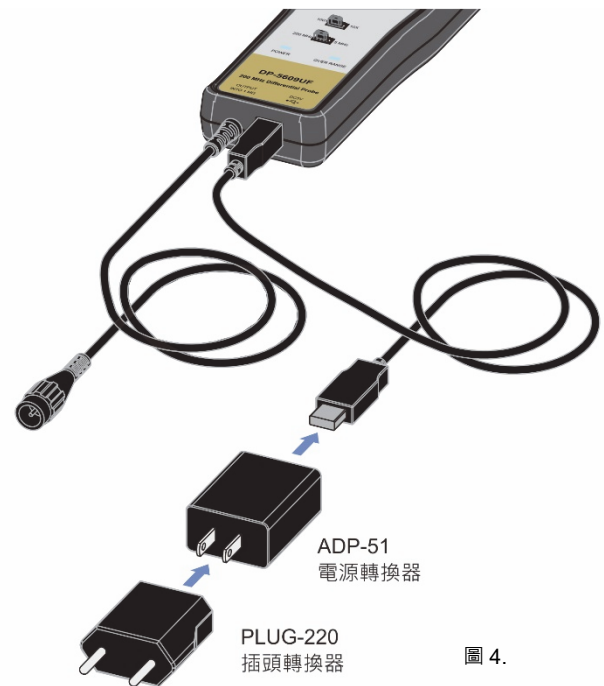

## 降額曲線

DP-5609UF 高頻耐壓曲線是以最大差模輸入電壓為例：

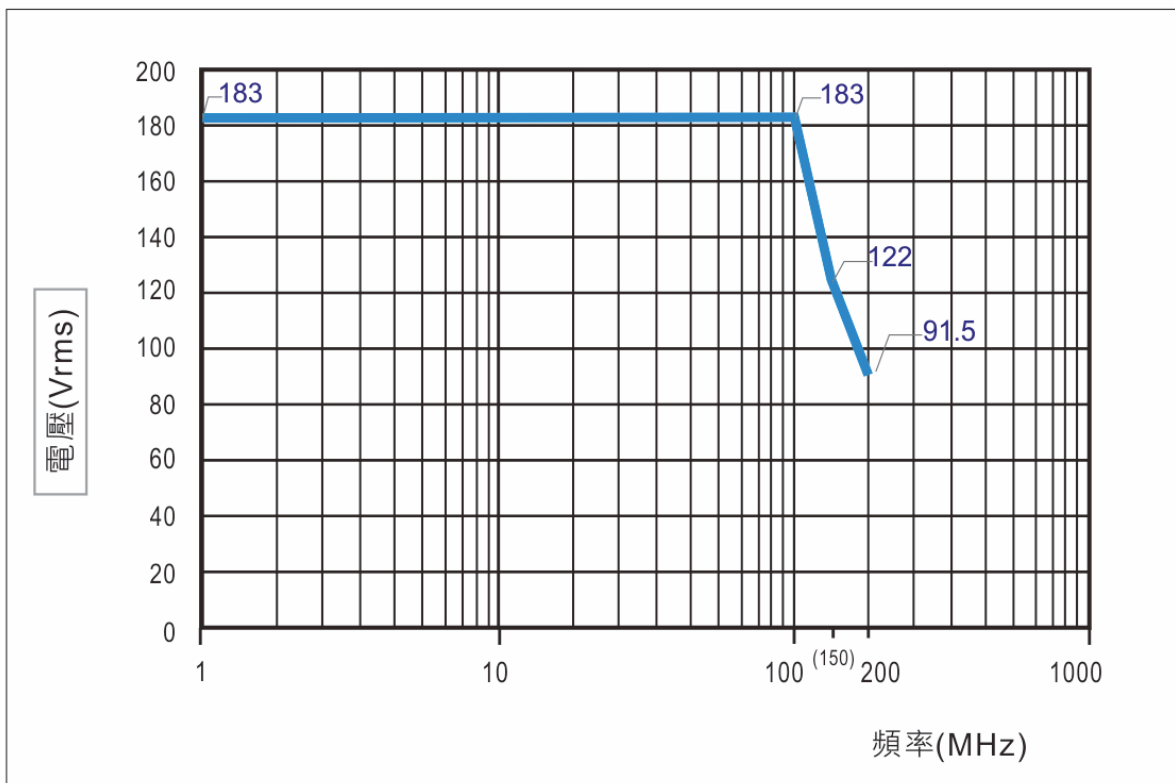

---

## 產品維護

保養此產品時請使用原廠指定的工具，原廠將不負任何責任由其他不被認可的維修人員所做的維修。

### 清潔

此產品不需要任何特定的清潔，如有需要，請用輕軟乾淨的棉布沾上微量的清潔液輕輕的在產品外觀擦拭。

### 保固

除了人為的特意損壞，本產品受保固並可以回原廠維修，但並不包含在安全規範的責任。

保固是以不超出發票上的金額，零件的更換及運送的費用。

保固是僅在正常操作下所造成的損壞，並不包含任何刻意的損壞、操作上的錯誤、機械上的操作不當、保養不當、負載或過壓等問題。

原廠的保固僅包含有限的單純更換損壞的零件，使用者將不可歸據直接或間接的責任在原廠。

原廠的保固是售出後的 12 個月內，如有任意的非原廠的維修或更換零件，原廠保固將自然取消。

### 維修

有任何的維修，保養或更換零件是在保固以外，請將產品退回原廠維修。

## ATTACHED/ 附圖

### Standard Accessories/ 標準附件示意圖



PS. Refer to P.4 attachment description. / 請參照 P.13 附件說明。



